

EMC Test Report



Product : LED BULB
Model Number : LT-HYD3W/4W/5W/7W,LT-GYD1W,LT-HYD-E14/G4/G9

Prepared for : LIGHTAC INDUSTRY CO., LIMITED
Address : NO.8, TANGFANG, TONGZHOU, NANTONG CITY,
JIANGSU,CHINA

Prepared By : Shanghai EU Test Technology Co.,Ltd.
Address : B-4-11 ZHANGJIANG HIGH-TECH PARK Pudong Xinqu,
Shanghai, China

Report No. : 17ZCTE113009ER

Date of Test : Dec. 04, 2017-Dec. 05, 2017

Date of Rep. : Dec. 06, 2017

Prepared by(Engineer):

Allen

Reviewer(Quality Manager):



Approved & Authorized Signer(Manager):

Tommy

Contents

	Page
COVER PAGE	
CONTENTS	2
1 TEST SUMMARY	4
1.1 MEASUREMENT UNCERTAINTY.....	5
2 TEST FACILITY	6
2.1 DEVIATION FROM STANDARD.....	6
2.2 ABNORMALITIES FROM STANDARD CONDITIONS.....	6
3 GENERAL INFORMATION	6
3.1 GENERAL DESCRIPTION OF EUT.....	6
3.1.1 EUT TEST MODE.....	6
4 EQUIPMENTS LIST FOR ALL TEST ITEMS	7
5 EMISSION TEST RESULTS	8
5.1 MAINS TERMINALS DISTURBANCE VOLTAGE MEASUREMENT.....	8
5.1.1 E.U.T. OPERATION.....	8
5.1.2 TEST SPECIFICATION.....	9
5.1.3 MEASUREMENT DATA.....	9
5.2 MAGNETIC EMISSION MEASUREMENT.....	12
5.2.1 E.U.T. OPERATION.....	12
5.2.2 TEST SPECIFICATION.....	12
5.2.3 MEASUREMENT DATA.....	12
5.3 RADIATED EMISSION MEASUREMENT.....	16
5.3.1 E.U.T. OPERATION.....	16
5.3.2 TEST SPECIFICATION.....	16
5.3.3 MEASUREMENT DATA.....	17
5.4 HARMONICS.....	19
5.4.1 E.U.T. OPERATION.....	19
5.4.2 TEST SPECIFICATION.....	19
5.4.3 MEASUREMENT DATA.....	19
5.5 VOLTAGE CHANGES, VOLTAGE FLUCTUATIONS AND FLICKER.....	20
5.5.1 E.U.T. OPERATION.....	20
5.5.2 TEST SPECIFICATION.....	20
5.5.3 MEASUREMENT DATA.....	20
6 IMMUNITY TEST RESULTS	21
6.1 ELECTROSTATIC DISCHARGE IMMUNITY TEST.....	21
6.1.1 E.U.T. OPERATION.....	21
6.1.2 TEST SPECIFICATION.....	21
6.1.3 MEASUREMENT DATA.....	21
6.2 RF FIELD STRENGTH IMMUNITY TEST.....	23
6.2.1 E.U.T. OPERATION.....	23
6.2.2 TEST SPECIFICATION.....	23
6.2.3 MEASUREMENT DATA.....	23
6.3 ELECTRICAL FAST TRANSIENT/BURST IMMUNITY TEST.....	25
6.3.1 E.U.T. OPERATION.....	25
6.3.2 TEST SPECIFICATION.....	25
6.3.3 MEASUREMENT DATA.....	26
6.4 SURGE IMMUNITY TEST.....	27
6.4.1 E.U.T. OPERATION.....	27
6.4.2 TEST SPECIFICATION.....	27
6.4.3 MEASUREMENT DATA.....	28

6.5 CONDUCTED DISTURBANCE IMMUNITY TEST.....	29
6.5.1 E.U.T. OPERATION.....	29
6.5.2 TEST SPECIFICATION.....	29
6.5.3 MEASUREMENT DATA.....	30
6.6 POWER FREQUENCY MAGNETIC FIELD IMMUNITY TEST.....	31
6.6.1 E.U.T. OPERATION.....	31
6.6.2 TEST SPECIFICATION.....	31
6.6.3 MEASUREMENT DATA.....	32
6.7 VOLTAGE DIPS AND INTERRUPTIONS IMMUNITY TEST.....	33
6.7.1 E.U.T. OPERATION.....	33
6.7.2 TEST SPECIFICATION.....	33
6.7.3 MEASUREMENT DATA.....	34
7 APPENDIX-PHOTOGRAPHS OF EUT CONSTRUCTIONAL DETAILS.....	35

1 Test Summary

Test procedures according to the technical standards:

<u>EMC Emission</u>				
Standard	Test Item	Limit	Judgment	Remark
EN 55015:2013/A1:2015	Conducted Emission	/	PASS	
	Magnetic Emission	/	PASS	
	Radiated Emission	/	PASS	
EN61000-3-2:2014	Harmonic Current Emission	Class C	PASS	
EN 61000-3-3:2013	Voltage Fluctuations & Flicker	-----	PASS	
<u>EMC Immunity</u>				
Section EN 61547:2009	Test Item	Performance Criteria	Judgment	Remark
EN 61000-4-2:2009	Electrostatic Discharge	B	PASS	
EN 61000-4-3:2006/A2:2010	RF electromagnetic field	A	PASS	
EN 61000-4-4:2012	Fast transients	B	PASS	
EN 61000-4-5:2014	Surges	B	PASS	
EN 61000-4-6:2014/AC:2015	Injected Current	A	PASS	
EN 61000-4-8:2010	Power Frequency Magnetic Field	A	PASS	
EN 61000-4-11:2004	Volt. Interruptions Volt. Dips	B	PASS	

NOTE:

- (1) "N/A" denotes test is not applicable in this Test Report
- (2) Voltage dip: 100% reduction – Performance Criteria **B**
Voltage dip: 30% reduction – Performance Criteria **C**
- (3) For client's request and manual description, the test will not be executed.

1.1 Measurement Uncertainty

The report uncertainty of measurement $y \pm U$, where expanded uncertainty U is based on a standard uncertainty Multiplied by a coverage factor of $k=2$, providing a level of confidence of approximately 95% .

No.	Item	Frequency Range	U , Value
1	Power Line Conducted Emission	9KHz~30MHz	1.58 dB
2	MAGNETIC EMISSION MEASUREMENT	9KHz~30MHz	2.00 dB
3	Disturbance Power Emission (Conduction 1)	30MHz~300MHz	3.12 dB
4	Radiated Emission Test	30MHz~1GHz	3.40 dB
5	Radiated Emission Test	1GHz~18GHz	3.30 dB

2 Test Facility

Shanghai EU Test Technology Co., Ltd.
B-4-11 ZHANGJIANG HIGH-TECH PARK Pudong Xinqu, Shanghai, China.

2.1 Deviation from standard

None

2.2 Abnormalities from standard conditions

None

3 General Information

3.1 General Description of EUT

Manufacturer:	LIGHTAC INDUSTRY CO., LIMITED
Manufacturer Address:	NO.8 TANGFANG, TONGZHOU, NANTONG CITY, JIANGSU, CHINA.
EUT Name:	LED BULB
Test Model No:	LT-HYD7W
Attached No.:	LT-HYD3W, LT-HYD4W, LT-HYD5W, LT-GYD1W, LT-HYD-E14/G4/G9
Brand Name:	N/A
Power Supply Range:	Input: AC 100-265V 50/60Hz
Test Power Supply:	Input: AC 230V 50Hz

3.1.1 EUT Test Mode

Mode 1	ON
--------	----

4 Equipments List for All Test Items

No.	Equipment	Manufacturer	Model No.	S/N	Cal date
1	EMI Test Receiver	R&S	ESCI	100612	2017-05-31
2	EMI Test Receiver	R&S	ESPI	100067	2017-05-31
3	Amplifier	HP	8447D	1937A02415	2017-05-31
4	Single Power Conductor Module	FCC	FCC-LISN-5-50-1-01-CISPR25	07118	2017-05-31
5	TRILOG Broadband Test-Antenna	SCHWARZBECK	VULB9163	9163-387	2017-05-31
6	Horn Antenna	SCHWARZBECK	BBHA9120A	B08000991-0021	2017-05-31
7	High Field Biconical Antenna	ELECTRO-METRICS	EM-6913	169	2017-05-31
8	Log Periodic Antenna	ELECTRO-METRICS	EM-6950	818	2017-05-31
9	Remote Active Vertical Antenna	ELECTRO-METRICS	EM-6892	354	2017-05-31
10	Power Clamp	SCHWARZBECK	MDS-21	3898	2017-05-31
11	Single Power Conductor Module	FCC	FCC-LISN-5-50-1-01-CISPR25	07254	2017-05-31
12	Teo Line Single Phase Module	SCHWARZBECK	NSLK8128	D-69124	2017-05-31
13	Positioning Controller	C&C	CC-C-1F	MF7802155	2017-05-31
14	Electrostatic Discharge Simulator	TESEQ	NSG437	128	2017-05-31
15	Fast Transient Burst Generator	SCHAFFNER	MODULA6150	34587	2017-05-31
16	Fast Transient Noise Simulator	Noiseken	FNS-105AX	31438	2017-05-31
17	Capacitive Coupling Clamp	TESEQ	CDN8014	25115	2017-05-31
18	Color TV Pattern Genenator	PHILIPS	PM5418	TM209966	N/A
19	Power Frequency Magnetic Field Gene	EVERFINE	EMS61000-8K	608085	2017-05-31
20	Triple-Loop Antenna	EVERFINE	LLA-2	607035	2017-05-31
21	10dB attenuator	SCHWARZBECK	MTAIMP-136	R65.90.0009	2017-05-31
22	AC Power Source	California Instrumnets	5001ix-400-N0	HK53570	2017-05-31
23	Power Analyzer	California Instrumnets	PACS-1	X71719	2017-05-31

5 Emission Test Results

5.1 Mains Terminals Disturbance Voltage Measurement

POWER LINE CONDUCTED EMISSION(Frequency Range 9KHz-30MHz)

FREQUENCY (MHz)	(dBuV)	
	Quasi-peak	Average
0.009-0.05	110	--
0.05-0.15	90-80	--
0.15 -0.5	66 - 56 *	56- 46 *
0.50 -5.0	56.00	46.00
5.0 -30.0	60.00	50.00

Note:

- (1) The tighter limit applies at the band edges.
- (2) The limit of " * " marked band means the limitation decreases linearly with the logarithm of the frequency in the range.

Detector:

Peak for pre-scan (9kHz Resolution Bandwidth)
Quasi-Peak & Average if maximized peak within 6dB of Average Limit

5.1.1 E.U.T. Operation

Temperature:	24°C	Humidity:	55% RH	Atmospheric Pressure:	101	Kpa
Test Mode:	Mode 1			The Worst Mode:	Mode 1	

5.1.2 Test Specification

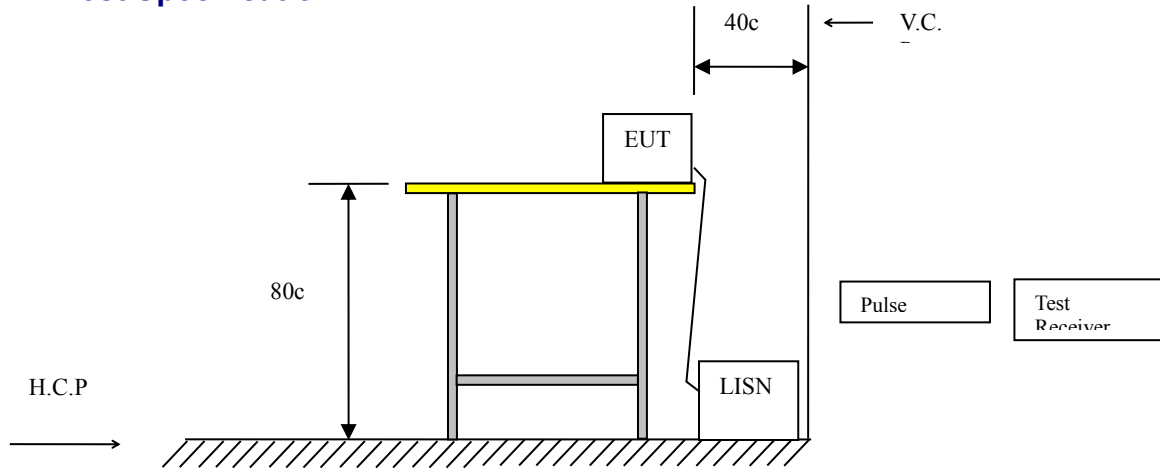

EUT was placed upon a wooden test table 0.8m above the horizontal metal reference plane and 0.4m from the vertical ground plane, and it was connected to an AMN. The closest distance between the boundary of the EUT and the surface of the AMN is 0.8m. All peripherals were connected to another AMN, and placed at a distance of 10cm from each other. A spectrum and receiver was connected to the RF output port of the AMN. Both average and quasi-peak value were detected.

5.1.3 Measurement Data

EUT:	LED BULB	Model No.:	LT-HYD7W
Temperature:	24 °C	Relative Humidity:	55%
Probe:	L	Test Power:	AC 230V/50Hz
Standard:	EN55015 Class B Conduction(QP)	Test Result:	Pass
Test Mode:	ON	Test By:	King

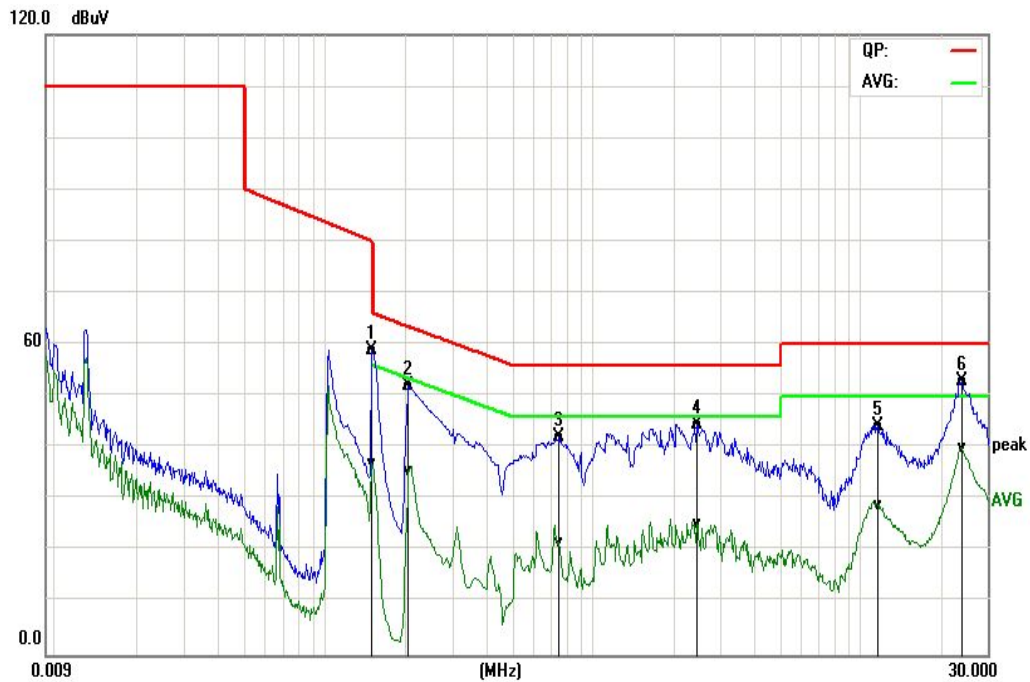

No.	Frequency (MHz)	QuasiPeak reading (dBuV)	Correction factor (dB)	QuasiPeak result (dBuV)	QuasiPeak limit (dBuV)	QuasiPeak margin (dB)	Remark
1	0.1500	58.88	0.04	58.92	66.00	-7.08	Pass
2	0.2060	52.03	0.04	52.07	63.37	-11.30	Pass
3	0.7540	42.08	0.06	42.14	56.00	-13.86	Pass
4	2.4660	44.34	0.11	44.45	56.00	-11.55	Pass
5	11.7060	44.13	0.23	44.36	60.00	-15.64	Pass
6*	24.1620	52.67	0.33	53.00	60.00	-7.00	Pass

EUT:	LED BULB	Model No.:	LT-HYD7W
Temperature:	24 °C	Relative Humidity:	55%
Probe:	N	Test Power:	AC 230V/50Hz
Standard:	EN55015 Class B Conduction(QP)	Test Result:	Pass
Test Mode:	ON	Test By:	King

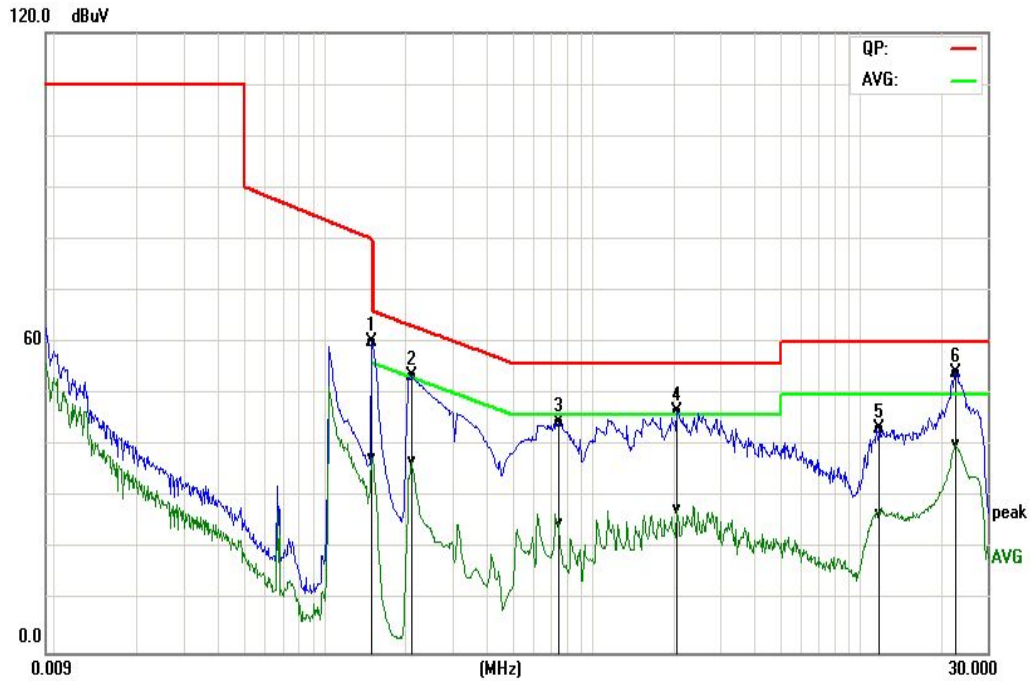

No.	Frequency (MHz)	QuasiPeak reading (dBuV)	Correction factor (dB)	QuasiPeak result (dBuV)	QuasiPeak limit (dBuV)	QuasiPeak margin (dB)	Remark
1*	0.1500	60.07	0.04	60.11	66.00	-5.89	Pass
2	0.2100	53.50	0.04	53.54	63.21	-9.67	Pass
3	0.7500	44.57	0.06	44.63	56.00	-11.37	Pass
4	2.0700	46.44	0.10	46.54	56.00	-9.46	Pass
5	11.8740	42.99	0.23	43.22	60.00	-16.78	Pass
6	22.8620	53.77	0.32	54.09	60.00	-5.91	Pass

5.2 MAGNETIC EMISSION MEASUREMENT

Frequency Range: 9kHz to 30MHz

Limits of Radiated Emission Measurement

Frequency	<input checked="" type="checkbox"/> 2m	<input type="checkbox"/> 3m	<input checked="" type="checkbox"/> 4m
	dB(μ A)		
9 KHz~ 70 KHz	88	81	75
70 KHz ~ 150 KHz	88 to 58(2)	81 to 51	75 to 45
150 KHz ~ 3 MHz ⁽¹⁾	58 to 22(2)	51 to 15	45 to 9
3 MHz ~ 30 MHz ⁽¹⁾	22	15 to 16	9 to 12

(1)The tighter limit applies at the band edges.

(2)The limit of " * " marked band means the limitation decreases linearly with the logarithm of the frequency in the range.

Detector:

Peak for pre-scan

Quasi-Peak if maximum peak within 6dB of limit

5.2.1 E.U.T. Operation

Temperature:	24.1°C	Humidity:	55% RH	Atmospheric Pressure:	101	Kpa
Test Mode:	Mode 1		The Worst Mode:		Mode 1	

5.2.2 Test Specification

EUT was placed upon a wooden test table which was placed in the center of the test antenna, and operating in the mode as mentioned above. A receiver is used to detect the actual value of each frequency which need to be checked. All three field directions were measured in sequence.

5.2.3 Measurement Data

An initial pre-scan was performed using the receiver in peak detection mode. The EUT was measured by 3 antenna position and peak emissions from the EUT were detected within 6dB of the class B limit line. The following quasi-peak measurements were performed on the EUT.

EUT:	LED BULB	Model No.:	LT-HYD7W
Temperature:	24.1 °C	Relative Humidity:	55%
Probe:	L1	Test Power:	AC 230V/50Hz
Standard:	EN55015 TRIPLE LOOP	Test Result:	Pass
Test Mode:	ON	Test By:	King



No.	Frequency (MHz)	Reading (dBuA/m)	Correct Factor(dB)	Result (dBuA/m)	Limit (dBuA/m)	Margin (dB)	Remark
1	0.1500	-4.24	45.72	41.48	58.00	-16.52	QP
2	0.3300	-20.07	45.73	25.66	48.53	-22.87	QP
3	0.6660	-25.27	45.65	20.38	40.09	-19.71	QP
4	1.5900	-25.46	45.33	19.87	29.63	-9.76	QP
5*	2.6660	-27.51	44.17	16.66	23.42	-6.76	QP
6	3.6220	-27.52	42.54	15.02	22.00	-6.98	QP

EUT:	LED BULB	Model No.:	LT-HYD7W
Temperature:	24.1 °C	Relative Humidity:	55%
Probe:	L2	Test Power:	AC 230V/50Hz
Standard:	EN55015 TRIPLE LOOP	Test Result:	Pass
Test Mode:	ON	Test By:	King



No.	Frequency (MHz)	Reading (dBuA/m)	Correct Factor(dB)	Result (dBuA/m)	Limit (dBuA/m)	Margin (dB)	Remark
1	0.1500	-5.24	45.72	40.48	58.00	-17.52	QP
2	0.3300	-20.07	45.73	25.66	48.53	-22.87	QP
3	0.7900	-25.62	45.67	20.05	38.03	-17.98	QP
4	1.5900	-26.46	45.33	18.87	29.63	-10.76	QP
5*	2.9420	-27.11	43.70	16.59	22.23	-5.64	QP
6	6.4140	-26.80	39.75	12.95	22.00	-9.05	QP

EUT:	LED BULB	Model No.:	LT-HYD7W
Temperature:	24.1 °C	Relative Humidity:	55%
Probe:	L3	Test Power:	AC 230V/50Hz
Standard:	EN55015 TRIPLE LOOP	Test Result:	Pass
Test Mode:	ON	Test By:	King



No.	Frequency (MHz)	Reading (dBuA/m)	Correct Factor(dB)	Result (dBuA/m)	Limit (dBuA/m)	Margin (dB)	Remark
1	0.1500	-5.24	45.72	40.48	58.00	-17.52	QP
2	0.3540	-19.11	45.74	26.63	47.68	-21.05	QP
3	0.7900	-25.62	45.67	20.05	38.03	-17.98	QP
4	1.5900	-25.46	45.33	19.87	29.63	-9.76	QP
5	1.9380	-37.57	45.31	7.74	27.25	-19.51	QP
6*	9.6980	-24.37	37.05	12.68	22.00	-9.32	QP

5.3 Radiated Emission Measurement

Limits of Radiated Emission Measurement (Below 1GHz)

Frequency (MHz)	<input type="checkbox"/> Class A (10m)	<input checked="" type="checkbox"/> Class B (3m)
	Quasi-Peak dB(μ V/m)	
30 ~ 230	40.0	40.0
230 ~ 300	47.0	47.0

Detector:

Peak for pre-scan (120kHz resolution bandwidth)

Quasi-Peak if maximum peak within 6dB of limit

5.3.1 E.U.T. Operation

Temperature:	24.3°C	Humidity:	55% RH	Atmospheric Pressure:	101	Kpa
Test Mode:	Mode 1			The Worst Mode:	Mode 1	

5.3.2 Test Specification

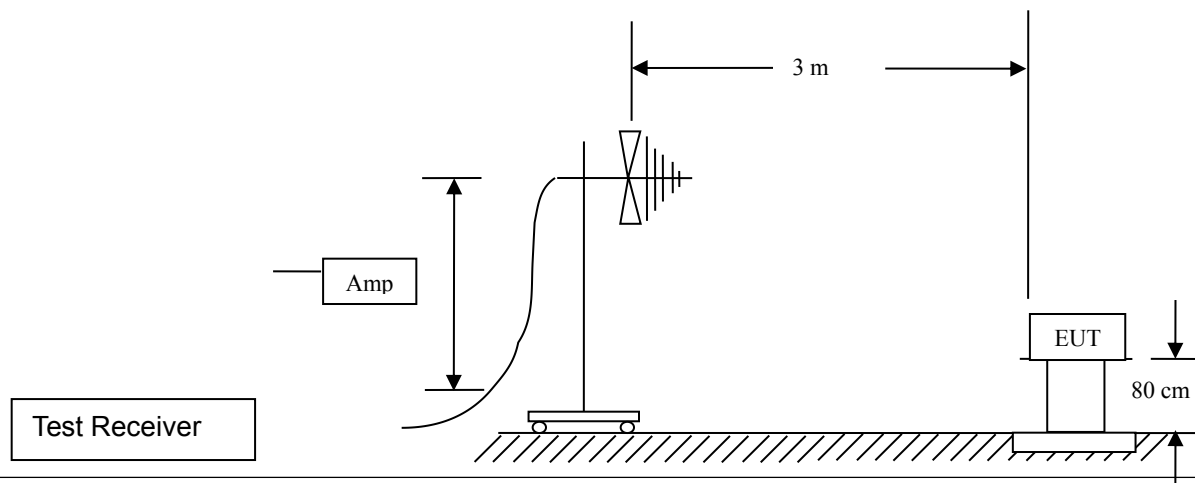

EUT was placed upon a wooden test table which was placed on the turn table 0.8m above the horizontal metal ground plane, and operating in the mode as mentioned above. A receiving antenna was placed 3m away from the EUT. During testing, turn around the turn table and move the antenna from 1m to 4m to find the maximum field-strength reading. All peripherals were placed at a distance of 10cm between each other. Both horizontal and vertical antenna polarities were tested.

5.3.3 Measurement Data

An initial pre-scan was performed in the 3m chamber using the spectrum analyzers in peak detection mode. The EUT was measured by Biology antenna with 2 orthogonal polarities and peak emissions from the EUT were detected within 6dB of the class B limit line.

The following quasi-peak measurements were performed on the EUT.

EUT:	LED BULB	Model No.:	LT-HYD7W
Temperature:	24.3°C	Relative Humidity:	55%
Distance:	3m	Test Power:	AC 230V/50Hz
Polarization:	Horizontal	Test Result:	Pass
Standard:	(RE)EN55015 class B 3m	Test By:	King

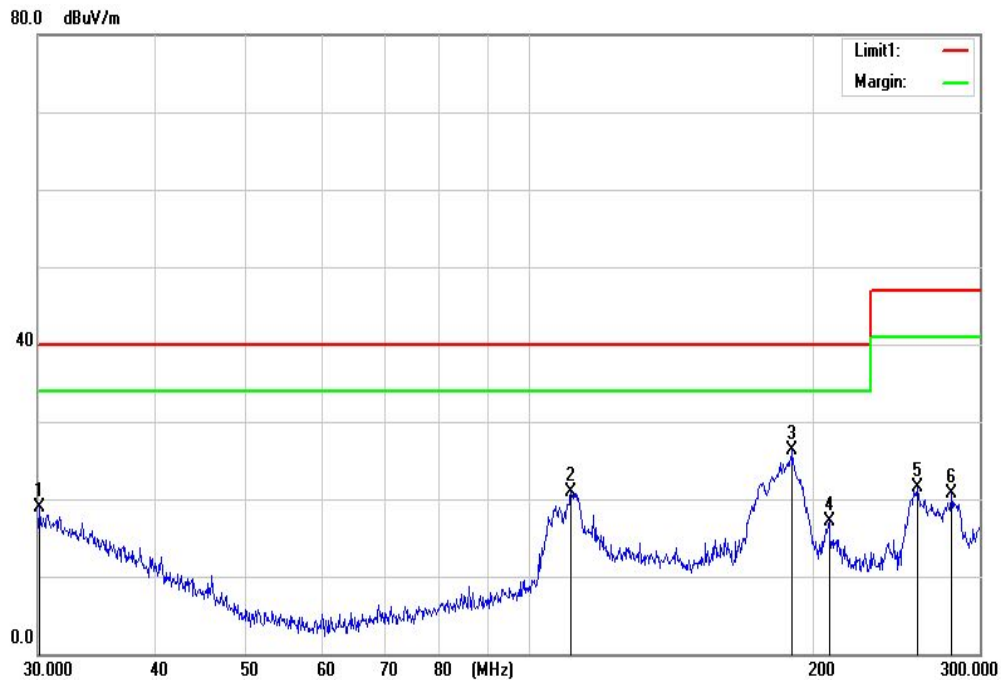

No.	Frequency (MHz)	Reading (dBuV)	Correct Factor(dB/m)	Result (dBuV/m)	Limit (dBuV/m)	Margin (dB)	Remark
1	30.1385	28.14	-9.24	18.90	40.00	-21.10	QP
2	110.4387	36.68	-15.87	20.81	40.00	-19.19	QP
3*	189.7236	44.38	-18.07	26.31	40.00	-13.69	QP
4	207.5493	34.93	-17.88	17.05	40.00	-22.95	QP
5	257.7041	37.14	-15.67	21.47	47.00	-25.53	QP
6	279.9763	34.28	-13.48	20.80	47.00	-26.20	QP

EUT:	LED BULB	Model No.:	LT-HYD7W
Temperature:	24.3°C	Relative Humidity:	55%
Distance:	3m	Test Power:	AC 230V/50Hz
Polarization:	Vertical	Test Result:	Pass
Standard:	(RE)EN55015 class B 3m	Test By:	King

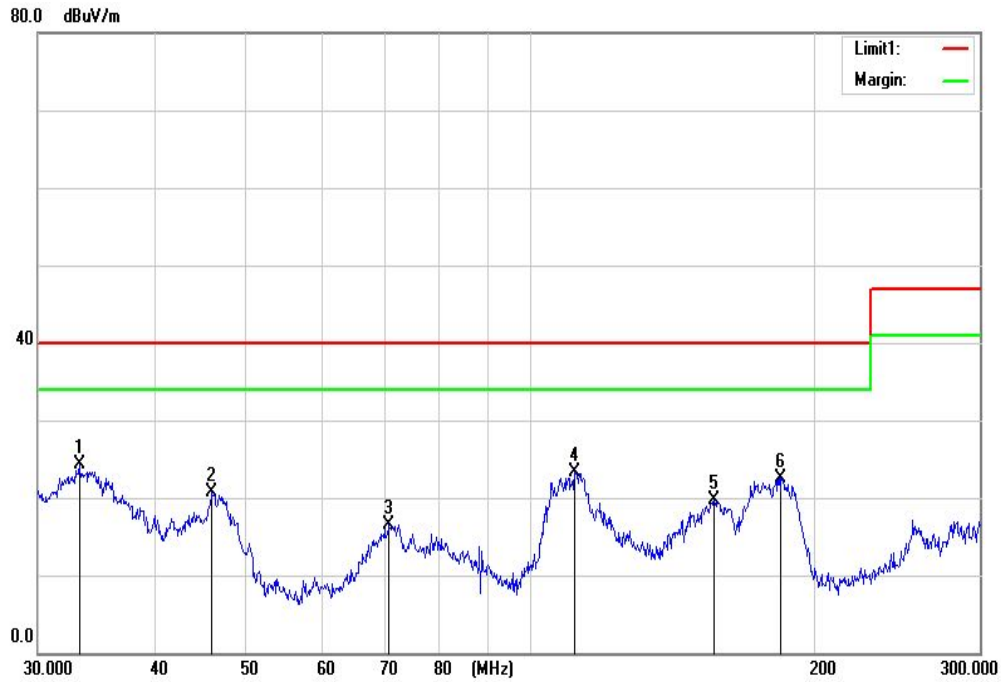

No.	Frequency (MHz)	Reading (dBuV)	Correct Factor(dB/m)	Result (dBuV/m)	Limit (dBuV/m)	Margin (dB)	Remark
1*	33.1987	35.41	-11.17	24.24	40.00	-15.76	QP
2	45.9326	40.28	-19.60	20.68	40.00	-19.32	QP
3	70.8143	39.45	-22.96	16.49	40.00	-23.51	QP
4	111.4606	39.04	-15.65	23.39	40.00	-16.61	QP
5	156.7189	35.63	-15.93	19.70	40.00	-20.30	QP
6	184.5531	40.51	-18.04	22.47	40.00	-17.53	QP

5.4 Harmonics

Frequency Range: 100Hz to 2kHz

Test Requirement: EN 61000-3-2

5.4.1 E.U.T. Operation

Temperature:	24.5°C	Humidity:	55% RH	Atmospheric Pressure:	101	Kpa
--------------	--------	-----------	--------	-----------------------	-----	-----

Test Mode:	Mode 1	The Worst Mode:	Mode 1
------------	--------	-----------------	--------

5.4.2 Test specification

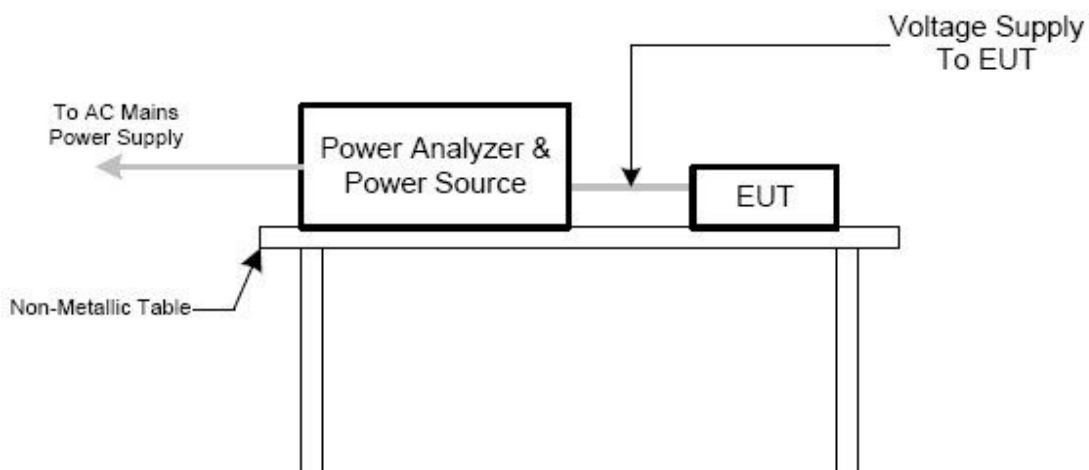

EUT operated in the mode as mentioned above, and connected to Harmonic/Flicker measuring equipment which was connected to an AC power source. Measurement was performed after EUT operating in static state for 10 seconds. Each order harmonics found to meet the relevant limits.

5.4.3 Measurement Data

PASS

5.5 Voltage changes, voltage fluctuations and flicker

Test Requirement: EN 61000-3-3

5.5.1 E.U.T. Operation

Temperature:	24.5°C	Humidity:	55% RH	Atmospheric Pressure:	101	Kpa
Test Mode:	Mode 1			The Worst Mode:	Mode 1	

5.5.2 Test specification

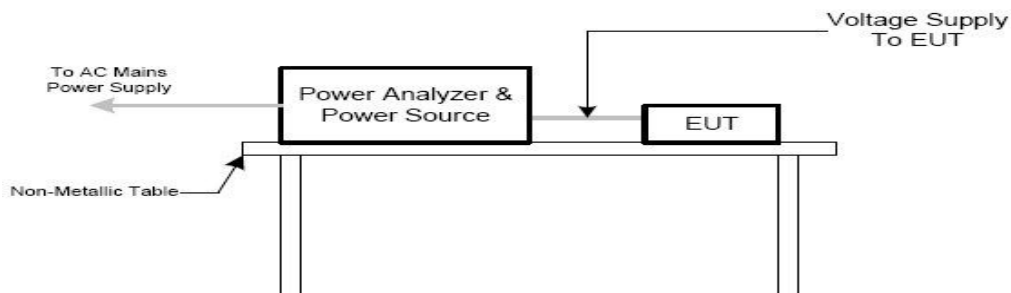

EUT was operated in the mode as mentioned above, and connected to Harmonic/Flicker measuring equipment which was connected to an AC power source.

5.5.3 Measurement Data

PASS

6 Immunity Test Results

6.1 Electrostatic discharge immunity test

Acceptable Performance Criterion:	B
Discharge Impedance:	330 Ω / 150 pF
Discharge Voltage:	Air Discharge: ± 8 kV
	Contact Discharge: ± 4 kV
	VCP, HCP: ± 4 kV
Polarity:	Positive & Negative
Minimum discharge Interval:	1 second

6.1.1 E.U.T. Operation

Temperature:	24.1°C	Humidity:	56% RH	Atmospheric Pressure:	101	Kpa
Test Mode:	Mode 1		The Worst Mode:	Mode 1		

6.1.2 Test specification

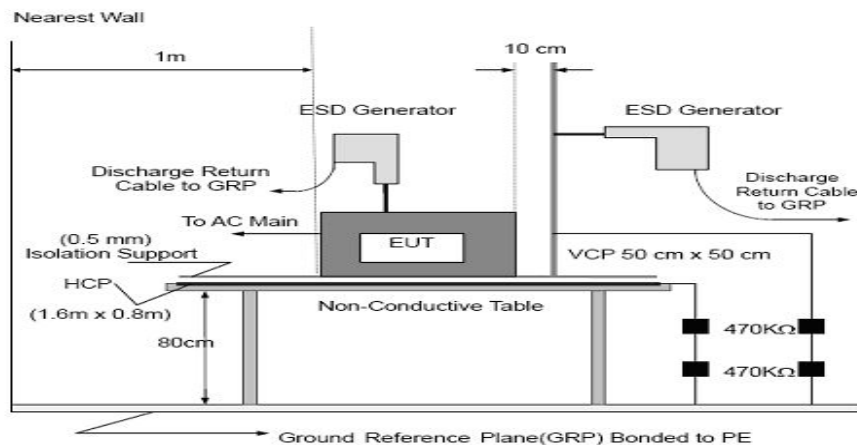

EUT was operated in the mode as mentioned above. Both contact and air discharge was executed. Contact discharge to the conductive surfaces and to coupling planes; air discharge at insulating surfaces. Each test point shall be subjected to 10 discharges at least (For each voltage and polarity).

6.1.3 Measurement Data

Test Record

Electrostatic Discharge Test Results																			
EUT: <u>LED BULB</u>										Test Date: <u>Dec. 05, 2017</u>				<input type="checkbox"/> IEC61000-4-2 <input checked="" type="checkbox"/> EN61000-4-2 <input type="checkbox"/> other:					
M/N: <u>LT-HYD7W</u>										Test Result: <input checked="" type="checkbox"/> Pass <input type="checkbox"/> Fail									
Test Voltage: <u>Input: AC 230V/50Hz</u>										Temp: <u>24.1</u> °C				Humi: <u>56</u> %					
										Atmospheric Pressure: <u>101</u> Kpa									
Operating Mode		ON																	
Discharge times		Contact discharge: minimum <u>10</u> times (+/-respectively) at each point, Air discharge: minimum <u>10</u> times (+/- respectively) at each point.																	
Discharge Mode		Air Discharge								Contact Discharge								Performance Criterion	Result
Test level (kV)		4		8		10		15		2		4		6		8			
Test Location		+	-	+	-	+	-	+	-	+	-	+	-	+	-	+	-		
HCP												A	A					B	Pass
VCP												A	A						Pass
Gap				B	B														Pass
Shell				B	B														Pass
Screw												B	B						Pass
Note: "P" means Pass , Horizontal Coupling Plane(HCP) and Vertical Coupling plane(VCP).																			

6.2 RF field strength immunity test

Acceptable Performance Criterion:	A
Test Level	3 V/m
Test Distance	3 m
Frequency Range	80MHz~1000MHz
Polarity:	Horizontal & Vertical

6.2.1 E.U.T. Operation

Temperature:	24.2°C	Humidity:	55% RH	Atmospheric Pressure:	101	Kpa
Test Mode:	Mode 1			The Worst Mode:	Mode 1	

6.2.2 Test specification

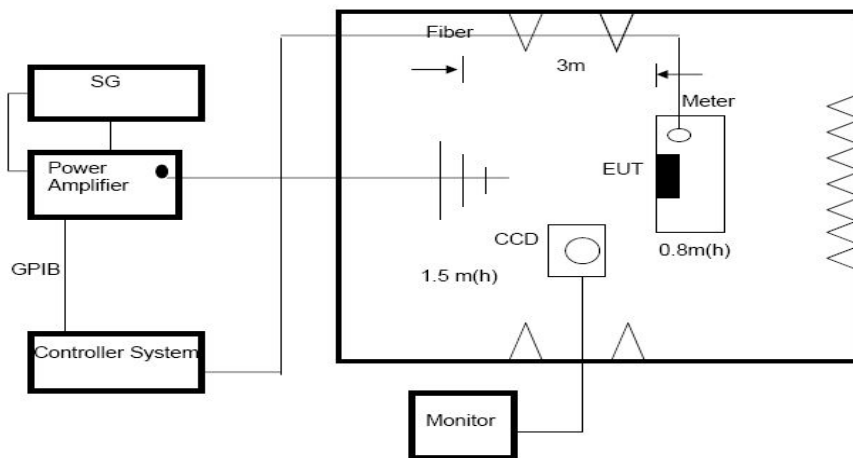

Test was executed in a fully Anechoic chamber. An antenna was used to transmit interference signal. EUT was placed upon a wooden table above the reference ground 0.8m, and was positioned so that the four sides of the EUT shall be exposed to the electromagnetic field in a sequence. In each position the performance of the EUT was investigated. A camera was used to monitor the loss of function or degradation of performance of the EUT.

6.2.3 Measurement Data

Test Record

Radiated Frequency Field Strength Susceptibility Results					
EUT: <u>LED BULB</u>		Test Date: <u>Dec. 05, 2017</u>		<input type="checkbox"/> IEC61000-4-3 <input checked="" type="checkbox"/> EN61000-4-3 <input type="checkbox"/> other:	
M/N: <u>LT-HYD7W</u>		Test Result: <input checked="" type="checkbox"/> Pass <input type="checkbox"/> Fail			
Test Voltage: <u>Input: AC 230V/50Hz</u>		Temp: <u>24.2</u> °C Humi: <u>55</u> %			
		Atmospheric Pressure: <u>101</u> Kpa			
Test Port	Input Port				
Operating Mode	Mode 1				
Test Level	<u>3</u> V/m(r.m.s) (unmodulated)			Criterion	
Frequency Range(MHz)	Antenna polarity	Modulation	EUT position	Result	
80~1000	Horizontal	1KHz, 80% AM	Front	Pass	
			Rear	Pass	
			Left	Pass	
			Right	Pass	
80~1000	Vertical	1KHz, 80% AM	Front	Pass	
			Rear	Pass	
			Left	Pass	
			Right	Pass	

6.3 Electrical fast transient/burst immunity test

Acceptable Performance Criterion:	B
Test Level:	0.5, 1.0, kV on AC Line
Repetition Frequency:	5 kHz
Burst Duration:	300 ms
Test Duration:	1 minutes for each level & polarity

6.3.1 E.U.T. Operation

Temperature:	24.5°C	Humidity:	54% RH	Atmospheric Pressure:	101	Kpa
Test Mode:	Mode 1		The Worst Mode:	Mode 1		

6.3.2 Test specification

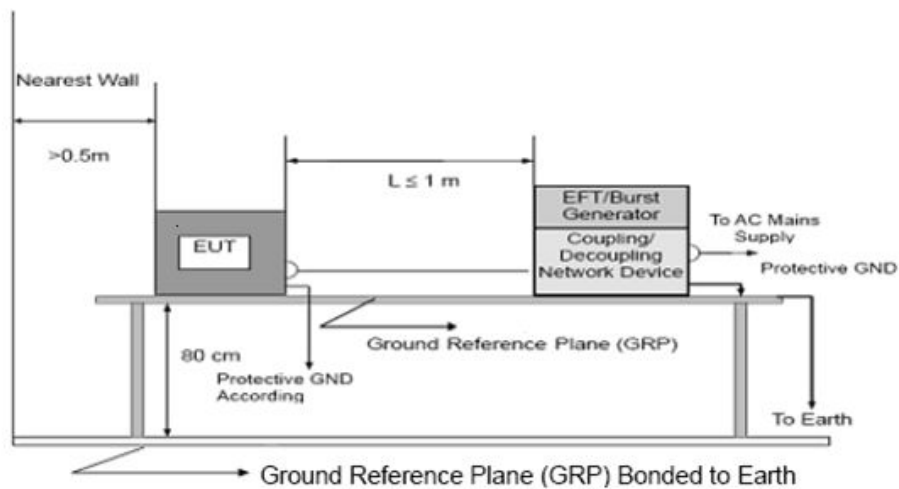

EUT was placed on a metal ground reference plane and was insulated from it by a wooden support which is 0.1m thick. The ground reference plane is connected to the protective earth. The test generator and the coupling/decoupling network were placed directly on, and bonded to the ground reference plane.

6.3.3 Measurement Data

Mode	(<input checked="" type="checkbox"/>) AC Power Line	(<input type="checkbox"/>) DC Power Line	(<input type="checkbox"/>) Signal/Control Line
Test Level	1KV		0.5KV
Port(s)	Polarity	Results	Polarity
Line (L)	P	A	P
	N	A	N
Neutral (N)	P	A	P
	N	A	N
Line + Neutral (L+N)	P	A	P
	N	A	N
Ground (PE)	P	A	P
	N	A	N
Line + Ground (L+PE)	P	A	P
	N	A	N
Neutral + Ground (N+PE)	P	A	P
	N	A	N
Line + Neutral+ Ground(L+N+PE)	P	A	P
	N	A	N
Signal/Control Line	P		P
	N		N
Criteria	B		B
Result	A		N/A
Judgment	PASS		N/A

Note:

- 1) P/N denotes the Positive/Negative polarity of the output voltage.
- 2) N/A - denotes test is not applicable in this test report
- 3) Criteria A: There was no change operated with initial operating during the test.
- 4) Criteria B: The EUT function loss during the test, but self-recoverable after the test.
- 5) Criteria C: The system shut down during the test.

6.4 Surge immunity test

Acceptable Performance Criterion:	B
Test Level:	0.5, 1kV Line to Neutral
	0.5, 1, 2kV Line, Neutral to Earth
Polarity:	Positive & Negative
Generator source impedance:	2 Ω & 12 Ω
Trigger Mode:	Internal
No. of surges:	5 positive & 5 negative at 90°, 270°.

6.4.1 E.U.T. Operation

Temperature:	24.2°C	Humidity:	56% RH	Atmospheric Pressure:	101	Kpa
Test Mode:	Mode 1			The Worst Mode:	Mode 1	

6.4.2 Test specification

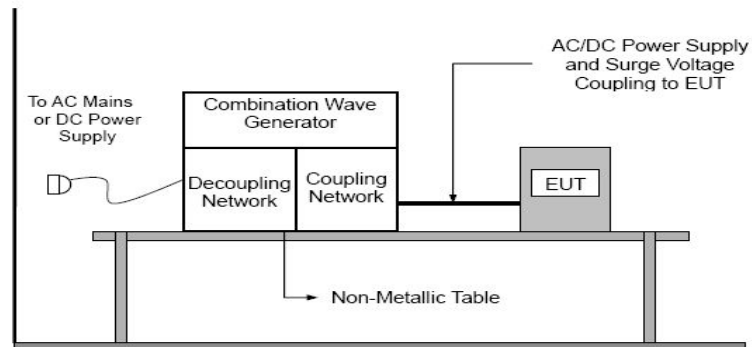

EUT was placed on a wooden table which is 0.8m above the ground and operated in the mode as mentioned above. The power cord between the EUT and the coupling/decoupling network was bundled so as to make it less than 2 m in length.

6.4.3 Measurement Data

Wave Form EUT Ports Tested	1.2/50(8/20)Ti/Th us						Criteria	Judgment
	Polarity	Phase	Voltage					
			0.5kV	1kV	1.5kV	2kV		
L - N	+/-	0°					B	PASS
	+/-	90°	A					
	+/-	180°						
	+/-	270°	A					
L - PE	+/-	0°					B	PASS
	+/-	90°	A					
	+/-	180°						
	+/-	270°	A					
N - PE	+/-	0°					B	PASS
	+/-	90°	A					
	+/-	180°						
	+/-	270°	A					
Signal Line (N/A)	+/-	0°					N/A	N/A
	+/-	90°						
	+/-	180°						
	+/-	270°						

Note:

- 1) +/- denotes the Positive/Negative polarity of the output voltage.
- 2) Polarity and Numbers of Impulses: 5 Pst / Ngt at each tested mode
- 3) N/A - denotes test is not applicable in this Test Report
- 4) All voltages of the lower levels shall be satisfied

6.5 Conducted disturbance immunity Test

Acceptable Performance Criterion:	A
Test Level	3 V
Frequency Range	0.150MHz~80MHz

6.5.1 E.U.T. Operation

Temperature:	24.2°C	Humidity:	55% RH	Atmospheric Pressure:	101	Kpa
Test Mode:	Mode 1			The Worst Mode:	Mode 1	

6.5.2 Test specification

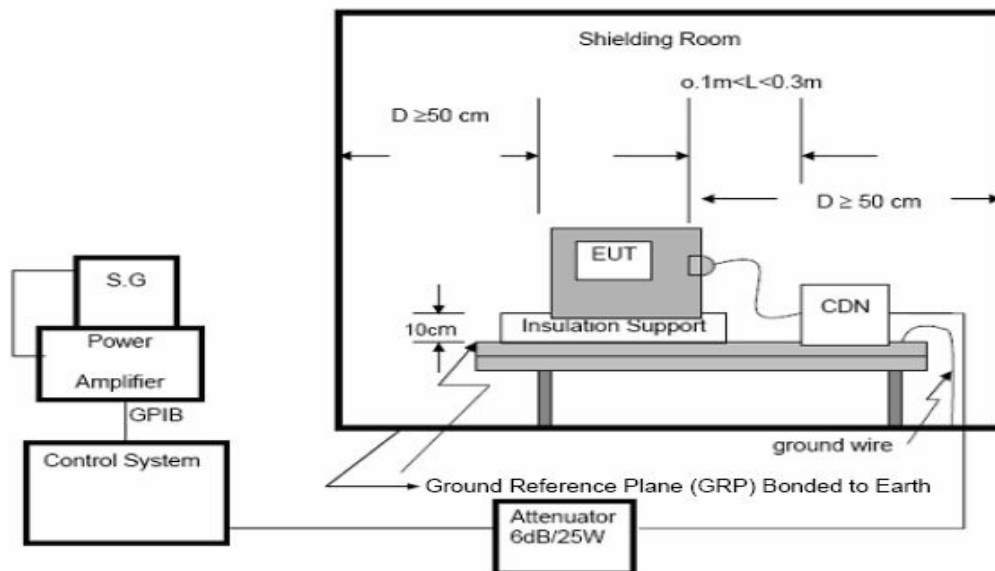

The equipment to be tested was placed on an insulating support of 0,1m height above a ground reference Plane. The minimum distance between the EUT and all other conductive structures, except the ground reference plane is more than 0.5m. All relevant cables were provided with the appropriate coupling and decoupling devices at a distance between 0.1m and 0.3m from the projected geometry of the EUT.

6.5.3 Measurement Data

Test Ports (Mode)	Freq. Range MHz)	Field Strength	Perform. Criteria	Results	Judgment
Input/ Output AC. Power Port	0.15 ---80	3V(rms) AM Modulated 1000Hz, 80%	A	A	PASS
Input/ Output DC. Power Port	0.15 --- 80		A	N/A	N/A
Signal Line (N/A)	0.15 --- 80		A	N/A	N/A

Note:

- 1) N/A - denotes test is not applicable in this Test Report.

6.6 Power frequency magnetic field immunity test

Acceptable Performance Criterion:	A
Test Level:	1 A/m
Coil Orientation:	X & Y & Z
Test Duration:	5 Minutes for each orientation

6.6.1 E.U.T. Operation

Operating Environment:						
Temperature:	24°C	Humidity:	56% RH	Atmospheric Pressure:	101	Kpa
EUT Operation:	Normal					

6.6.2 Test specification

The equipment is configured and connected to satisfy its functional requirements. It was placed on the ground reference plane with the interposition of a 0.1 m thickness wooden support and was placed in the center of the induction coil. All cables (include power cord and signal line) were exposed to the magnetic field for at least 1m of their length.

6.6.3 Measurement Data

Test Record

Power Frequency Magnetic Field Immunity Test Results				
EUT: <u>LED BULB</u>		Test Date: <u>Dec. 05, 2017</u>		
M/N: <u>LT-HYD7W</u>		Test Result: <input checked="" type="checkbox"/> Pass <input type="checkbox"/> Fail		
Test Voltage: <u>Input: AC 230V/50Hz</u>		Temp: <u>24</u> °C , Humi: <u>56</u> %		
		Atmospheric Pressure: <u>101</u> Kpa		
Operating Mode	Normal			
Test Level	Test Duration	Coil Orientation	Criterion	Result
<u>1</u> A/m	<u>5</u> minus	X	A	Pass
<u>1</u> A/m	<u>5</u> minus	Y	A	Pass
<u>1</u> A/m	<u>5</u> minus	Z	A	Pass
Notes: None				

6.7 Voltage dips and interruptions immunity test

Acceptable Performance Criterion:	B & C
Test Level:	<5% of U_T (Supply Voltage) for 0.5 and 250 Periods
	70 % of U_T (Supply Voltage) for 25 Periods
No. of Dips / Interruptions:	3 per Level

6.7.1 E.U.T. Operation

Temperature:	24°C	Humidity:	56% RH	Atmospheric Pressure:	101	Kpa
Test Mode:	Mode 1			The Worst Mode:	Mode 1	

6.7.2 Test specification

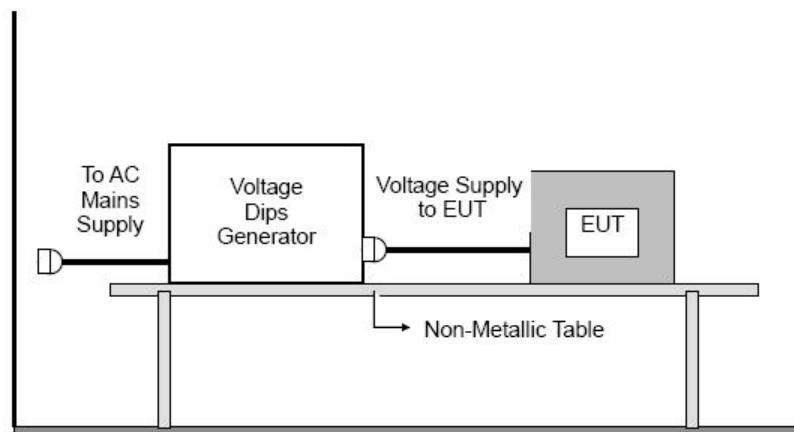

EUT connected to the test generator with the shortest power supply cable as specified by the EUT manufacturer. The rated voltage of the EUT was used as the basis for voltage test level specification. After each group of tests, a full functional check was performed.

6.7.3 Measurement Data

<u>Voltage Reduction</u>	Periods	Perform Criteria	Results	Judgment
Voltage dip > 95%	0.5	B	A	PASS
Voltage dip 30%	25	C	A	PASS

7 APPENDIX-Photographs of EUT Constructional Details



Photo 1



Photo 2



Photo 3

******End of Report******